

LE 60

LAVAOGGETTI SOTTOBANCO



NEW
AVAILABLE AS OF
MAY 2023

 **500x600 mm**

 **22 pz.**

 **max 400 mm**

LE 60 è la nuova lavaoggetti sottobanco targata Elframo. Le **dimensioni compatte** la rendono adatta a qualsiasi ambiente, anche in presenza di spazi molto ridotti. **Robusta e potente**, è la soluzione ideale per la pulizia di teglie, contenitori GN, placche da forno, vassoi e piccoli utensili, ma si presta anche al lavaggio di stoviglie, bicchieri e posate. Pulito perfetto ed igiene garantita anche contro lo sporco più ostinato, **massima affidabilità e semplicità di utilizzo** in qualsiasi applicazione.

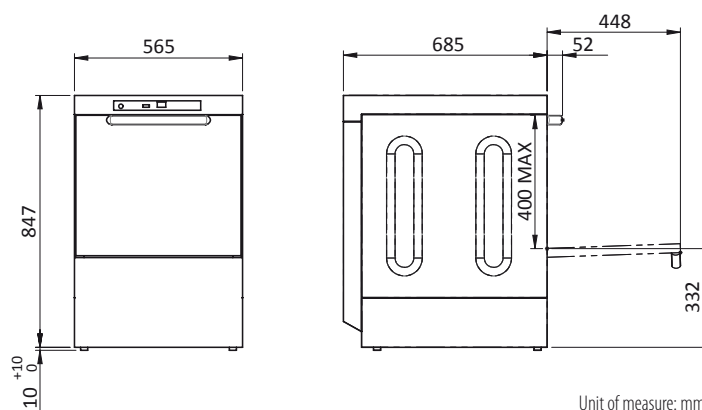

Unit of measure: mm

D4910000 LE 60 3.786,00 €
D4910100 LE 60 PR 3.996,00 €
D4911000 LE 60 PS 3.956,00 €

00007231 inserto teglie - grid for baking pans 130,00 €

FR LAVE-OBJET SOUS LE COMPTOIR

LE 60 est la nouvelle lave-objet sous le comptoir de Elframo. Son format compact s'adapte à chaque espace, aussi dans les plus étroits. Robuste et performante, c'est la solution idéale pour le nettoyage de casseroles, bacs GN, plaques de cuisson, plateaux et petits ustensiles, mais elle se prête aussi au nettoyage des assiettes, verres et couverts. Nettoyage parfait et hygiène garantie, aussi pour les salissures plus tenaces. Fiabilité maximale et facilité d'emploi à chaque application.

EN UNDERCOUNTER UTENSIL WASHER

LE 60 is the new Elframo undercounter utensil washer. The compact dimensions make it suitable for any environment, even in the presence of very small spaces. Sturdy and powerful, it is the ideal solution for cleaning trays, GN containers, oven plates, trays and small utensils, but it is also suitable for washing crockery, glasses and cutlery. Perfect cleaning and guaranteed hygiene even against the most stubborn dirt, maximum reliability and ease of use in any application.

ES LAVAOBJETOS EMPOTRADOS

LE 60 es la nueva lavavajilla empotrada de Elframo. Sus dimensiones compactas la hacen adecuada para cualquier entorno, incluso cuando el espacio es reducido. Robusto y potente, es la solución ideal para limpiar bandejas, recipientes GN, placas de horno, bandejas y pequeños utensilios, pero también es adecuado para lavar platos, vasos y cubiertos. Limpieza perfecta e higiene garantizada incluso frente a la suciedad más incrustada, máxima fiabilidad y facilidad de uso en cualquier aplicación.

DE UNTERTISCH-GERÄTESPÜLMASCHINE

LE 60 ist die neue Elframo Untertisch-Gerätespülmachine. Die kompakten Abmessungen machen es für jede Umgebung geeignet, auch bei sehr kleinen Räumen. Robust und leistungsstark, ist es die ideale Lösung zum Reinigen von Backformen, GN-Behältern, Ofenplatten, Tablett und Kleinutensilien, und eignet sich aber auch zum Spülen von Geschirr, Gläsern und Besteck. Perfekte Reinigung und garantierte Hygiene auch bei hartnäckigsten Verschmutzungen, maximale Zuverlässigkeit und einfache Handhabung in jeder Anwendung.





IT CARATTERISTICHE

- Telaio e scocca in acciaio inox AISI 304
- Comandi digitali: display per la visualizzazione delle temperature di vasca e boiler, indicazione programmi di lavaggio e messaggi d'errore
- Pompa di lavaggio da 0.81 kW (1.1 hp)
- Mulinelli di lavaggio e di risciacquo rotanti in acciaio inox
- Resistenza vasca e boiler in Incoloy 800
- Dispositivo attesa boiler
- Doppio dosatore brillantante e dosatore detersivo peristaltico

ACCESSORI OPZIONALI

- Pompa risciacquo
- Pompa scarico
- Potenza resistenza boiler 8.3 kW

FR CARACTÉRISTIQUES

- Châssis et carrosserie en acier inox AISI 304
- Contrôle numérique: affichage des températures, indication des programmes de lavage et des messages d'erreur
- Pompe de lavage 0.81 kW (1.1 hp)
- Bras de lavage et de rinçage rotatifs en inox
- Résistance cuve et chauffe-eau en Incoloy 800
- Dispositif d'attente chauffe-eau
- Double doseur péristaltiques pour produit de rinçage et produit lessiviel

ACCESSOIRES EN OPTION

- Pompe de rinçage
- Pompe de vidange
- Puissance résistance surchauffeur 8.3 kW

ES CARACTERÍSTICAS

- Construido totalmente en acero inoxidable AISI 304
- Mandos digitales: visualización de las temperaturas, indicación de los programas de lavado y mensajes de error
- Bomba de lavado 0.81 kW (1.1 hp)
- Brazos de lavado y aclarado giratorios en acero inox
- Resistencia de cuba y caldera en Incoloy 800
- Dispositivo de espera del boiler
- Doble dosificador de abrillantador y de detergente peristáltico

ACCESORIOS OPCIONALES

- Bomba de aclarado
- Bomba de desagüe
- Potencia de la resistencia de la caldera 8.3 kW

EN FEATURES

- AISI 304 stainless steel frame and body
- Digital controls: display for tank and boiler temperatures, indication of washing programs and alarms
- 0.81 kW (1.1 hp) wash pump
- Stainless steel rotating wash and rinse arms
- Tank and boiler heating elements in Incoloy 800
- Boiler holding device
- Double peristaltic rinse-aid and detergent doser

OPTIONAL ACCESSORIES

- Booster pump
- Drain pump
- Additional boiler heating element 8.3 kW

DE MERKMALE

- Rahmengestell und Gehäuse aus Edelstahl AISI 304
- Digitale Steuerung: Display von Tank- und Kesseltemperaturen, Anzeige von Spülprogrammen und Fehlermeldungen
- Spülpumpe zu 0,81 kW (1,1 hp)
- Rotierende Spül- und Nachspülarms aus Edelstahl
- Heizwiderstände für Becken und Boiler aus Incoloy 800
- Verzögerungseinrichtung für Boiler
- Doppeltes, peristaltisches Glanzspülmittel- und Spülmitteldosiergerät

OPTIONALES ZUBEHÖR

- Nachspülpumpe
- Ablaufpumpe
- Verstärkter Heizkörper Boiler 8,3 kW

SPECIFICHE TECNICHE • SPÉCIFICATIONS TECHNIQUES • ESPECIFICACIONES TECNICAS • TECHNICAL SPECIFICATIONS • TECHNISCHE SPEZIFIKATIONEN

Dimensioni (BxHxP) - Dimension (LxHxP) - Medidas (BxHxP) - Size (WxHxD) - Dimensionen (BxHxT)	565 x 847 x 685 mm
Peso netto/lordo - Poids net/brut - Peso neto/peso bruto - Net/gross weight - Nettogewicht/Bruttogewicht	65 Kg - 70 Kg
Dimensioni cesto - Dimension panier - Medidas del cesto - Basket sizes - Abmessungen Spülkorb	500x600 mm
Durata cicli - Durée cycles - Duración de los ciclos - Cycle lengths - Dauer Spülprogramme	60/120/180"
Tensione alimentazione - Alimentation électrique - Tensión de alimentación - Power rating - Versorgungsspannung	400V 3N @50 Hz
Potenza massima assorbita - Puissance maximale absorbée - Potencia máxima absorbida - Max absorbed power - Max. Leistungsaufnahme	6.91 kW
Potenza pompa - Puissance pompe - Potencia de la bomba - Pump power - Pumpenleistung	0.81 kW
Potenza resistenza boiler - Puissance résistance surchauffeur - Potencia de la resistencia de la caldera - Additional boiler heating element - Heizkörper Boiler	6.1 kW
Potenza resistenza vasca - Puissance résistance cuve - Potencia de la resistencia de la cuba - Tank heating element power - Leistung Heizelement Becken	3 kW
Consumo acqua - Consommation eau - Consumo de agua - Water consumption - Wasserverbrauch	3 l
Temperatura alimentazione acqua - Température alimentation eau - Temperatura de alimentación del agua - Main water temperature - Temperatur Wasserversorgung	55 ÷ 60 °C



500x600 mm



GN1/1 - h 20 mm



GN1/1 - h 40 mm



GN1/1 - h 65 mm



cm 60x40 - h 70 mm